

Datalogger ATV & Truck Installation

- 1. Install the flow switch on the sprayer making sure that only the flow that goes to the spray output nozzles is flowing through the switch, including the hand gun.**
 - Any flow from agitation or bypass going through the flow switch will cause the Datalogger to take incorrect GPS Points.
- 2. Run the gray-shielded wire to the front of the ATV or Truck near where the Datalogger is going to sit.**
 - It is best to locate the Datalogger in a position where it can be seen easily, like the rack or handle bars. It must be in the open for GPS signal reception. Some users use the GPS speedometer for sprayer speed and tracking.
- 3. On the flow switch attach either red wire of the switch to the green wire in the gray-shielded wire. Next attach the other red wire of the flow switch to the white wire in the gray-shielded wire.**
 - The red and black wires in the gray-shielded wire are used to power the Datalogger and can be hooked to power at the battery. It is recommended that battery power be used to keep the Datalogger and GPS receiver from turning off during the day.
 - Power can be tap from any battery location like the fuse box, or on models with a cigarette lighter tap, by installing a cigarette lighter plug. (Cigarette lighter taps are usually not hot and turn off with the key. For this reason it is not recommended tapping into power at this location.)
- 4. Plug in to the Datalogger; make sure the power is connected and test.**
- 5. For help please e-mail us at redsfixit3@redsfixit.com**

Please provide a description of the problem, a contact phone number, and return e-mail address and we will respond as soon as we can.

Installation Wiring Diagram

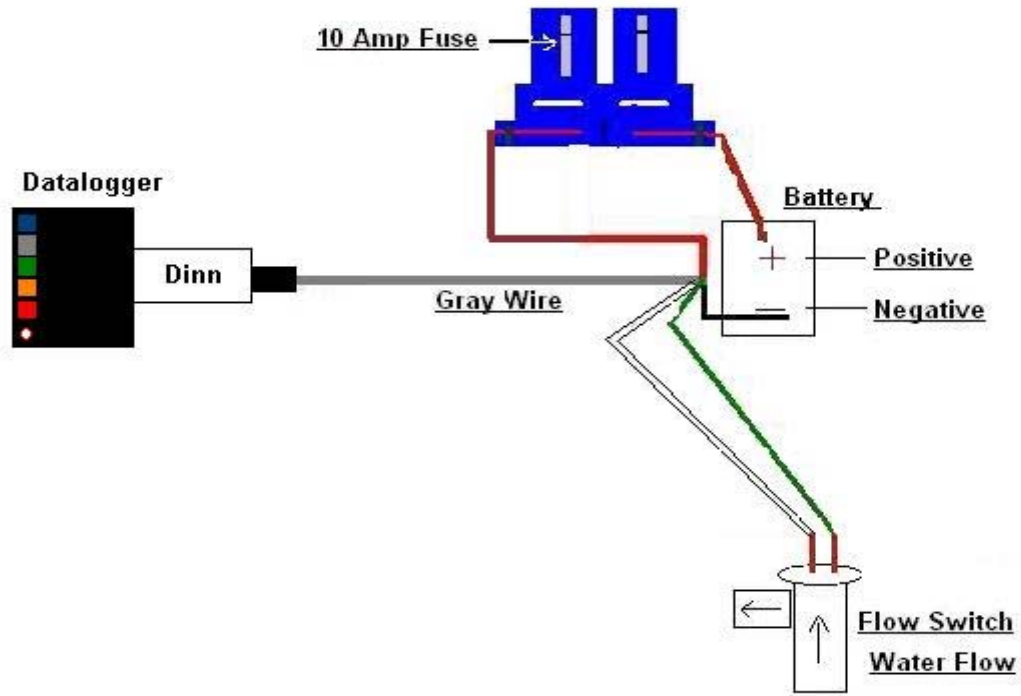

Thanks for using MAP products!